

STATE OF NORTH CAROLINA
DEPARTMENT OF TRANSPORTATION
HIGHWAY DIVISION 6

PLANS

Letting Date: December 20, 2023

CONTRACT ID: D6BR.POC.025

TIP NO.: -----

FEDERAL AID NO.: STATE FUNDED

WBS ELEMENT NO.: 6B.202614.2 & 6B.204314.2

ROUTE NO.: SR 1002 & SR 1280

LOCATION: VARIOUS

COUNTY: CUMBERLAND & HARNETT

LENGTH OF PROJECT: VARIOUS

TYPE OF WORK: PIPE REMOVAL & REPLACEMENTS

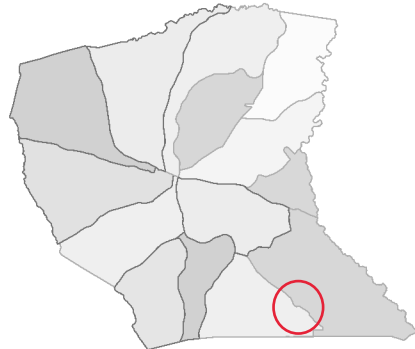
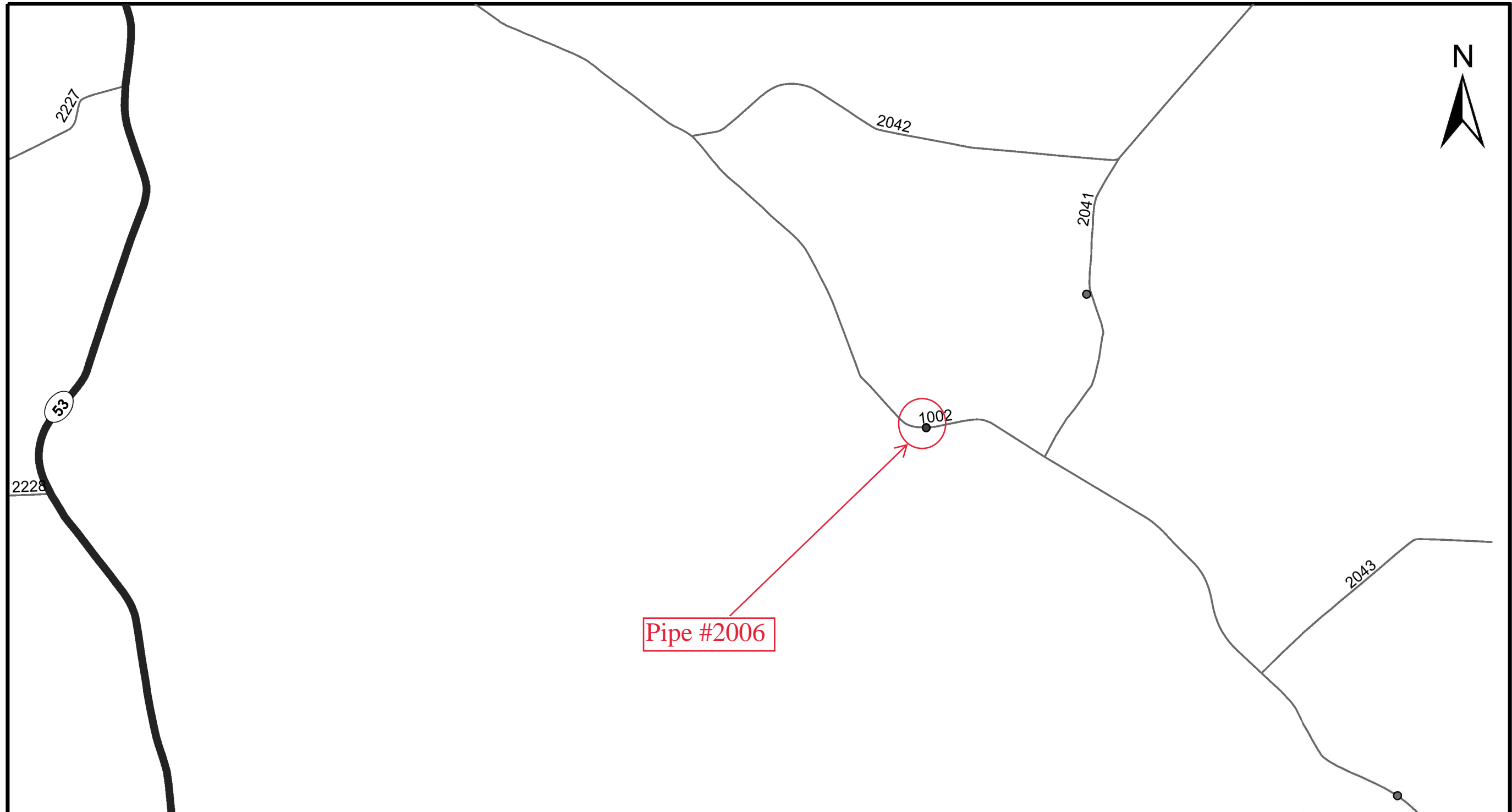

**VICINITY MAP - SR 1002, Turnbull Road
0.4 Miles NW of SR 2041**

Cumberland County
GPS: 34.888758, -78.675926

2023

NCDOT Division 6 Bridge Maintenance



COUNTY:	CUMBERLAND
LOCATION:	SR 1002, BP-025-2006
EXISTING:	2= 96"X70" CMP W/HWs
EXISTING:	1= 20'-6"X7'-3" ABC W/HW

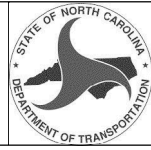

LAYOUT FOR FIELD INSTALLATION
ROADWAY CENTERLINE ELEV. = 100.0

SCALE - 1" = 10'

PROFILE LAYOUT

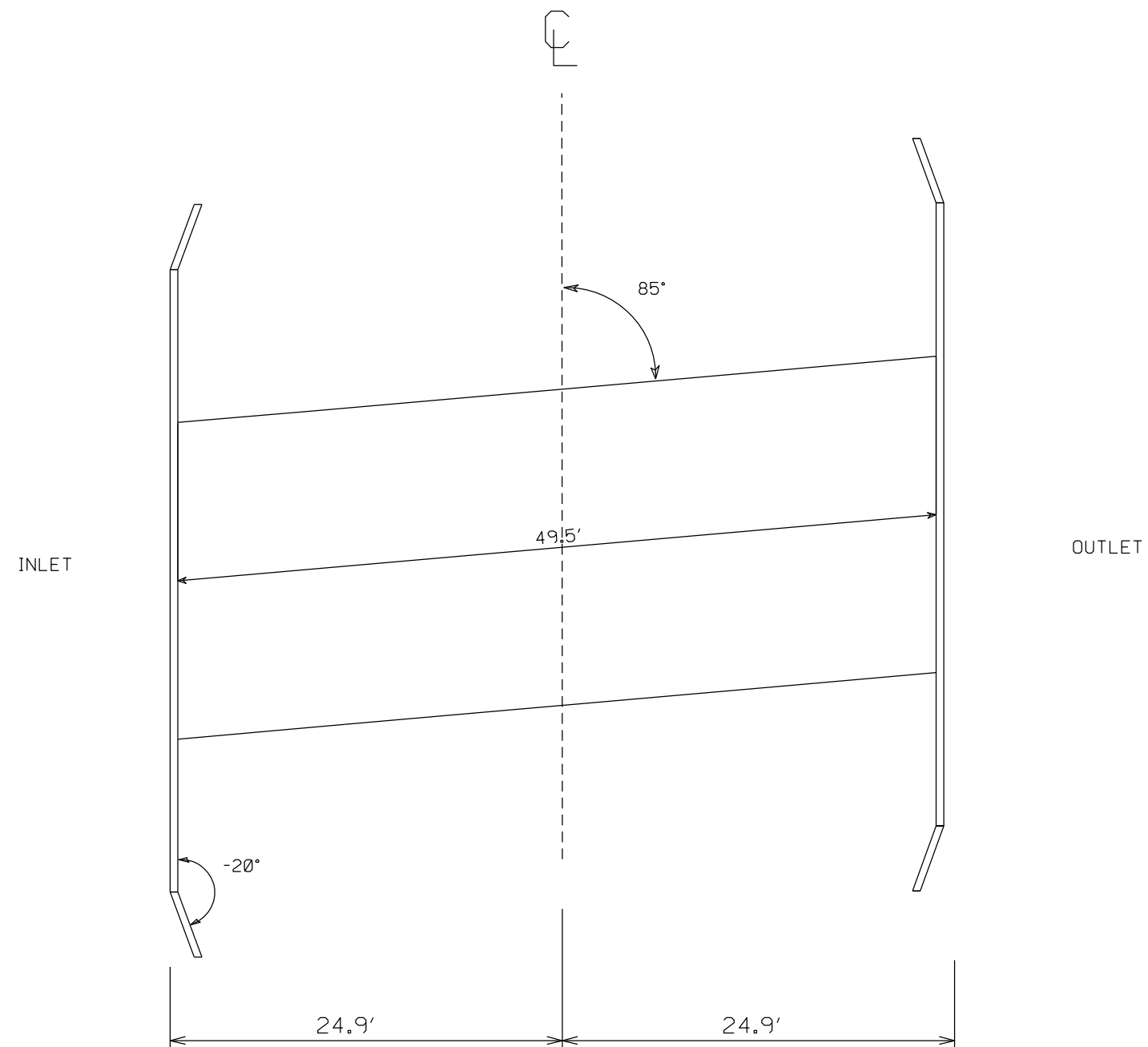

* REFERENCE ONLY -
Tieback and Wellbeam
Locations to be
determined in
Engineered Design

TOTAL LF = 49.5'

COUNTY:	CUMBERLAND
LOCATION:	SR 1002, BP-025-2006
EXISTING:	2= 96"X70" CMP W/HWs
EXISTING:	1= 20'-6"X7'-3" ABC W/HW



LAYOUT FOR FIELD INSTALLATION
ROADWAY CENTERLINE ELEV. = 100.0

SCALE - 1" = 10'

INLET HEADWALL

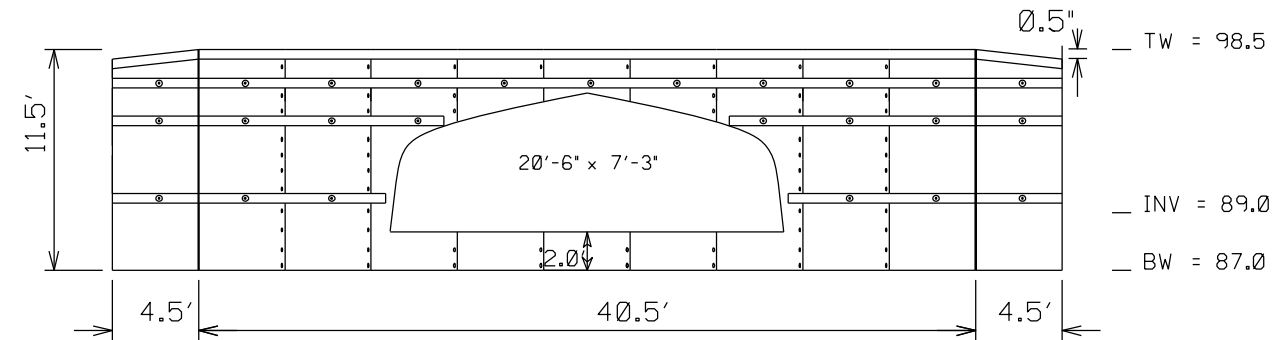

OUTLET HEADWALL

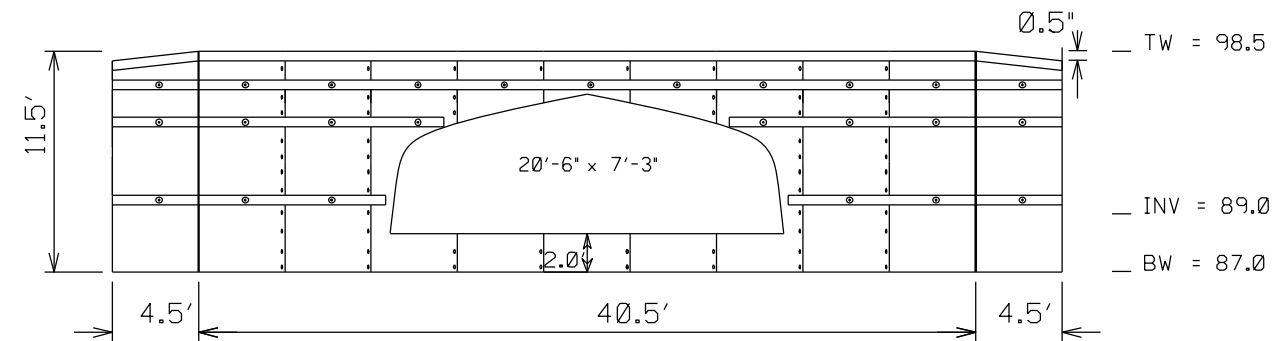

* REFERENCE ONLY -
Tieback and Wellbeam
Locations to be
determined in
Engineered Design

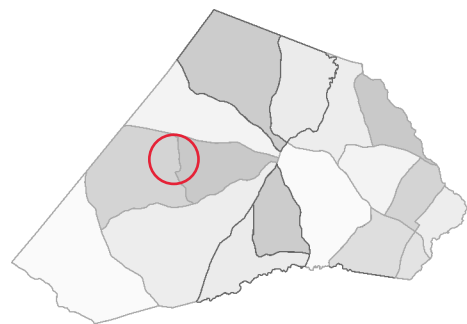
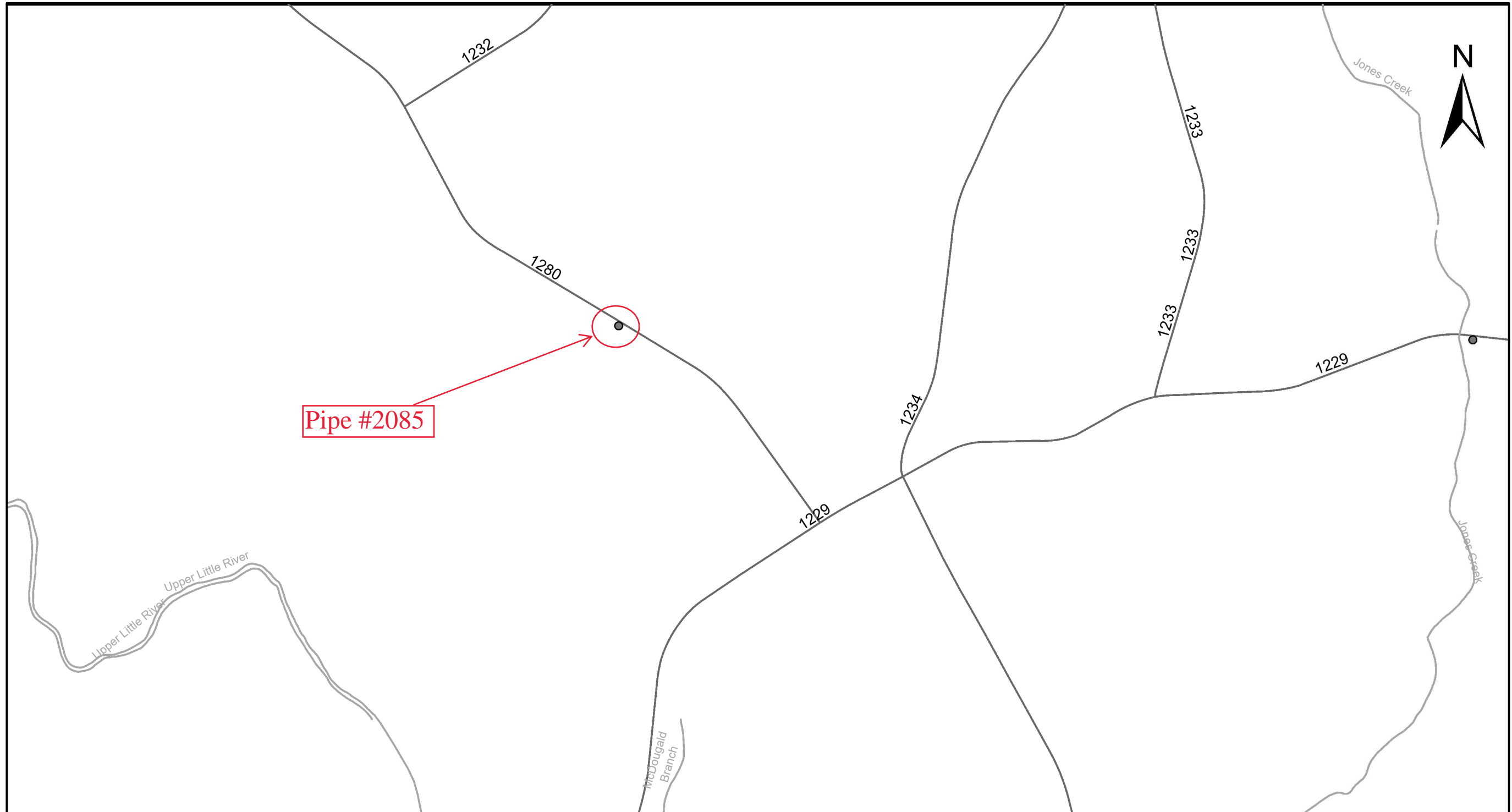

**VICINITY MAP - SR 1280, McArthur Road
0.5 Miles NW of SR 1229**

Harnett County
GPS: 35.384528, -78.982444

2023

NCDOT Division 6 Bridge Maintenance



COUNTY: HARNETT
LOCATION: SR 1280, MCARTHUR RD.
EXISTING: 1= 90" CMP w/HWs
EXISTING: 1= 11'-1"X7'-0" SPPA W/HW\$

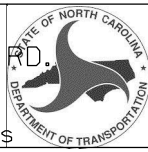

LAYOUT FOR FIELD INSTALLATION
ROADWAY CENTERLINE ELEV. = 100.0

SCALE - 1" = 10'

PROFILE LAYOUT

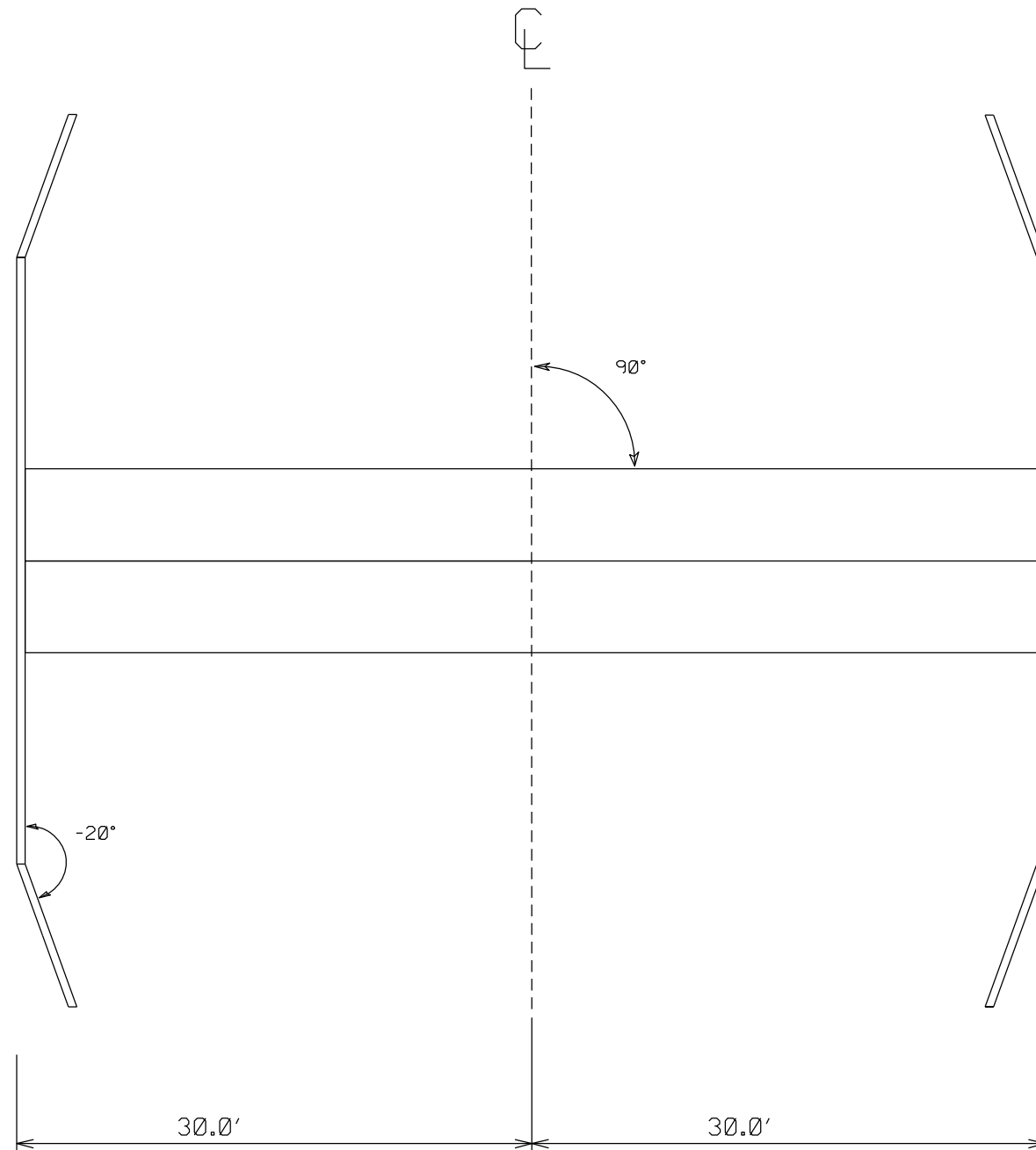

* REFERENCE ONLY -
Tieback and Wellbeam
Locations to be
determined in
Engineered Design

TOTAL LF = 60'

COUNTY:	HARNETT
LOCATION:	SR 1280, MCARTHUR RD.
EXISTING:	1= 90" CMP w/HWs
EXISTING:	1= 11'-1"X7'-0" SPPA W/HWs



LAYOUT FOR FIELD INSTALLATION
ROADWAY CENTERLINE ELEV. = 100.0

SCALE - 1" = 10'

INLET HEADWALL

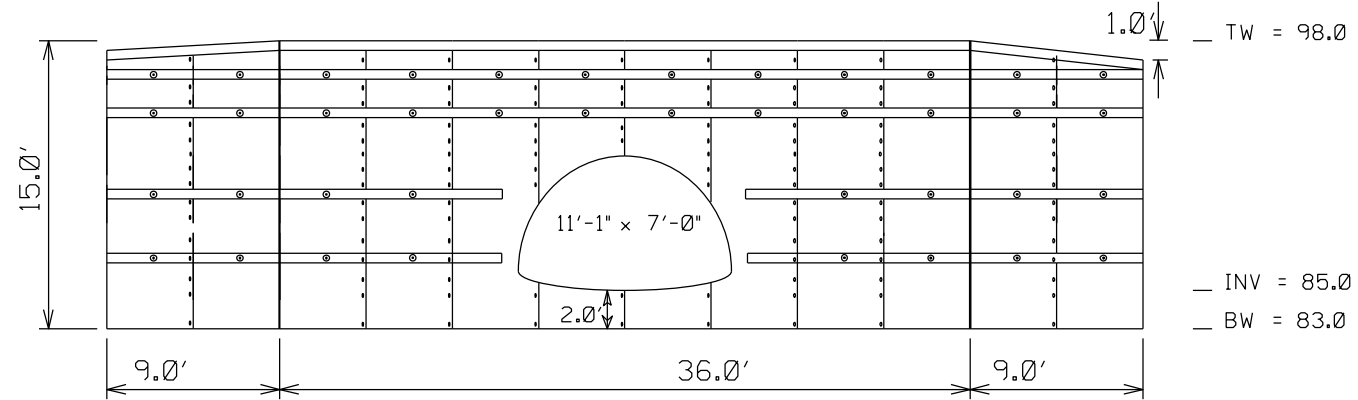

OUTLET HEADWALL

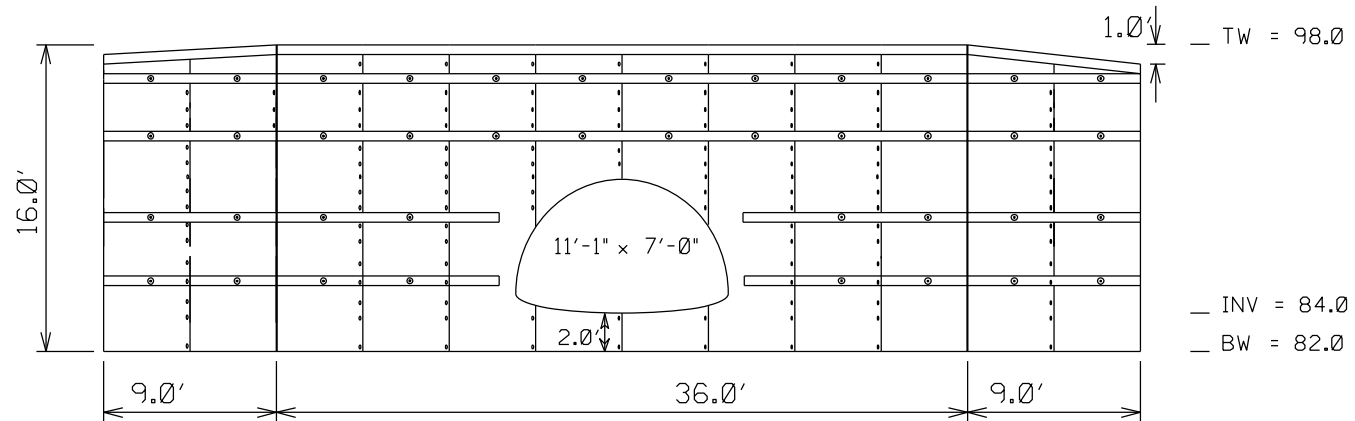

* REFERENCE ONLY -
Tieback and Wellbeam
Locations to be
determined in
Engineered Design

PAVEMENT SCHEDULE	
C1	1½" ASPHALT CONCRETE SURFACE COURSE, TYPE S9.5B, AT AN AVERAGE RATE OF 168 LBS. PER SQ. YD.
D1	3" ASPHALT CONCRETE INTERMEDIATE COURSE, TYPE AT I19.0C, AN AVERAGE RATE OF 285 LBS. PER SQ. YD.
T1	SHOULDER RECONSTRUCTION WITH SHOULDER BORROW
J	PROPOSED APPROX. 12" AGGREGATE BASE COURSE
U	EXISTING ASPHALT PAVEMENT DEPTH VARIES

* ASPHALT PLACEMENT SHALL BE PERFORMED IN ACCORDANCE WITH THE MOST CURRENT ASPHALT QUALITY MANAGEMENT SYSTEM (QMS) MANUAL & 2018 STANDARD SPECIFICATIONS

ROADWAY TYPICAL SECTION

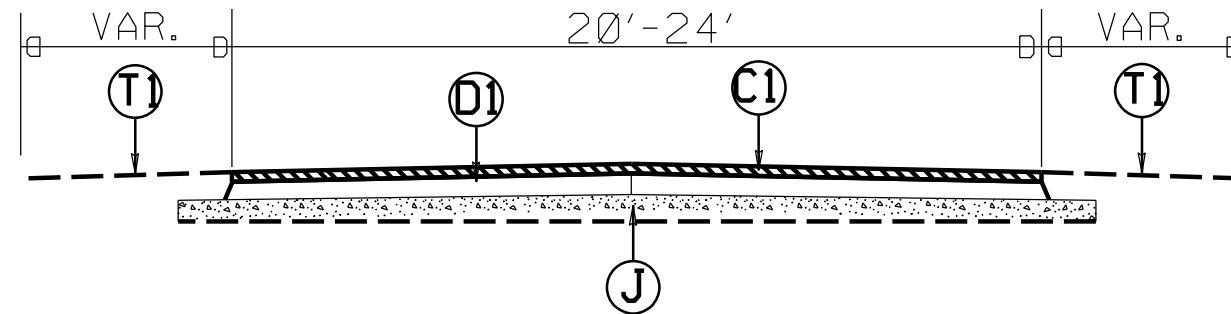

TYPICAL SECTION PROFILE NO. 1

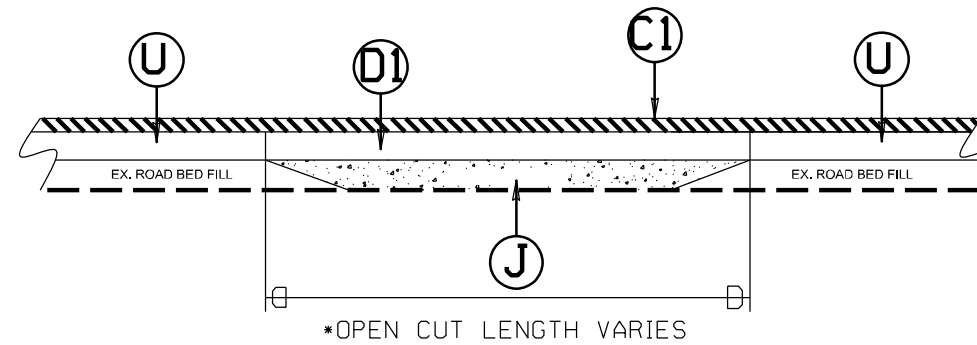

TYPICAL SECTION PROFILE NO. 2

*PAVEMENT SCHEDULE "D1" SHALL MATCH EXISTING ASPHALT GRADE & SLOPE

*CORE SAMPLES ARE REQUIRED

PROJECT LIMITS TYPICAL SECTION

* ALL WORK SHALL BE PERFORMED WITHIN THE PROJECT LIMITS OF 300' & THE NCDOT RIGHT-OF-WAY. ALL REPAIRS OUTSIDE OF THE PROJECT LIMITS SHALL BE THE RESPONSIBILITY OF THE CONTRACTOR AND MADE IN ACCORDANCE WITH THE 2018 STANDARD SPECIFICATIONS AT NO COST TO THE DEPARTMENT.

* S9.5B CONCRETE ASPHALT PLACEMENT SHALL NOT EXCEED A MAXIMUM OF 150' FROM THE CENTERLINE OF EXCAVATION AND TRANSITION TO EXISTING WEARING SURFACE.

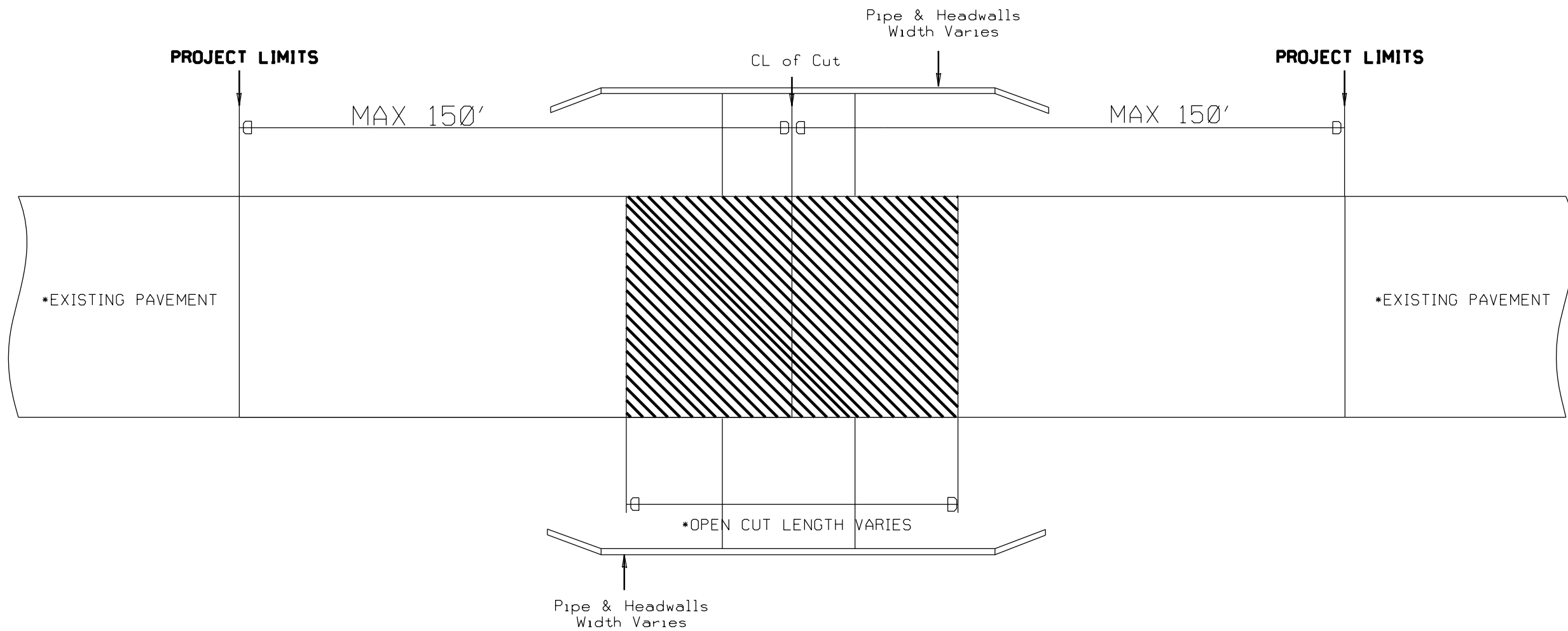



TYPICAL DRAWING SODDING

GENERAL NOTES

Sod shall be placed on the shoulders within construction limits of Pipe/Structure replacement. Sod shall be placed from Edge of pavement to the top of headwall, Rip Rap or Shoulder point on the Inlet & Outlet. Sod placement shall extend 25' from the structure's edge ahead and back.

- * All other disturbed areas shall be seeded and mulched per Contract & Standard Specifications.
- * Matting may be used in lieu of Mulch and Tack.

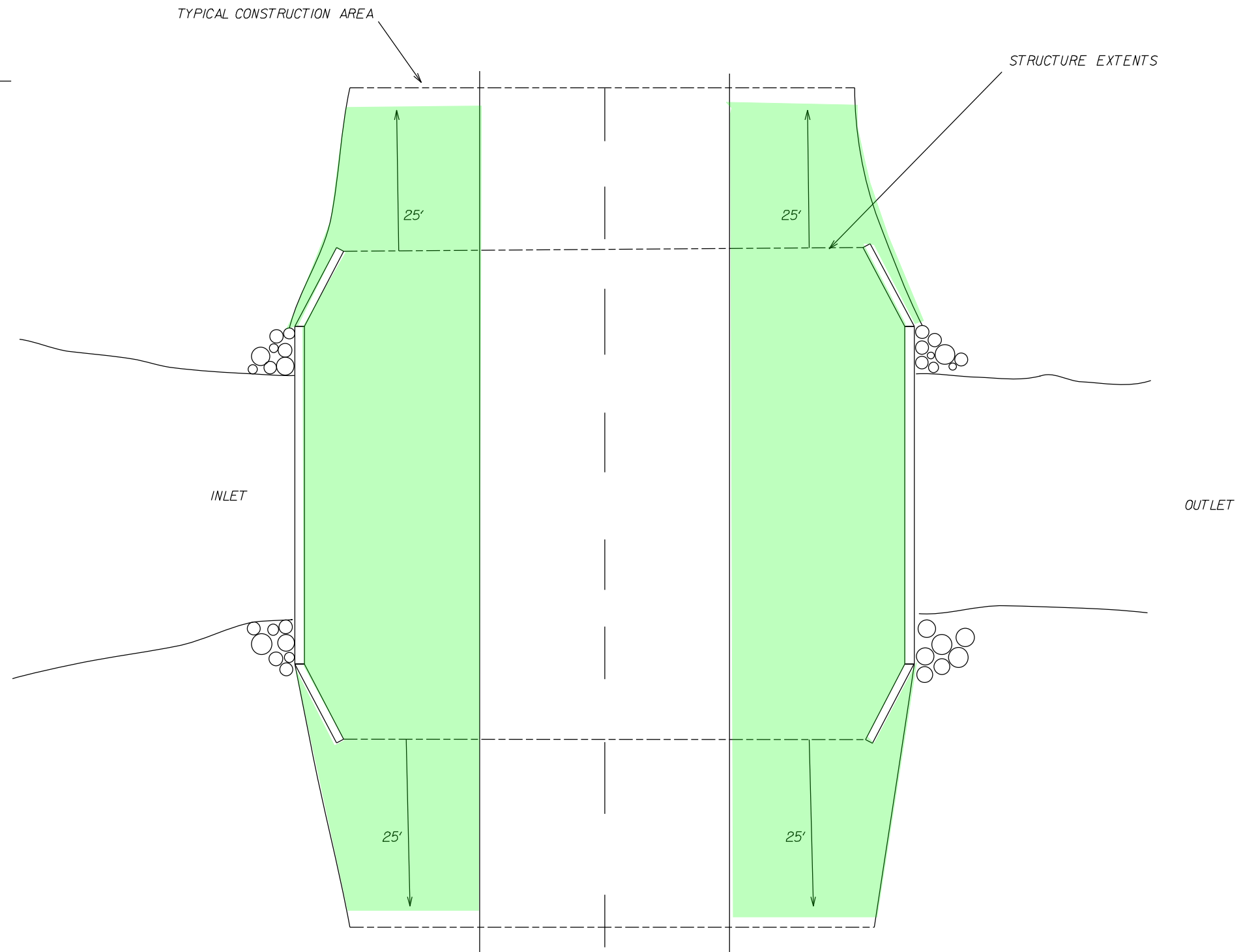

MANAGING THE WATERCOURSE: BYPASS PUMPING

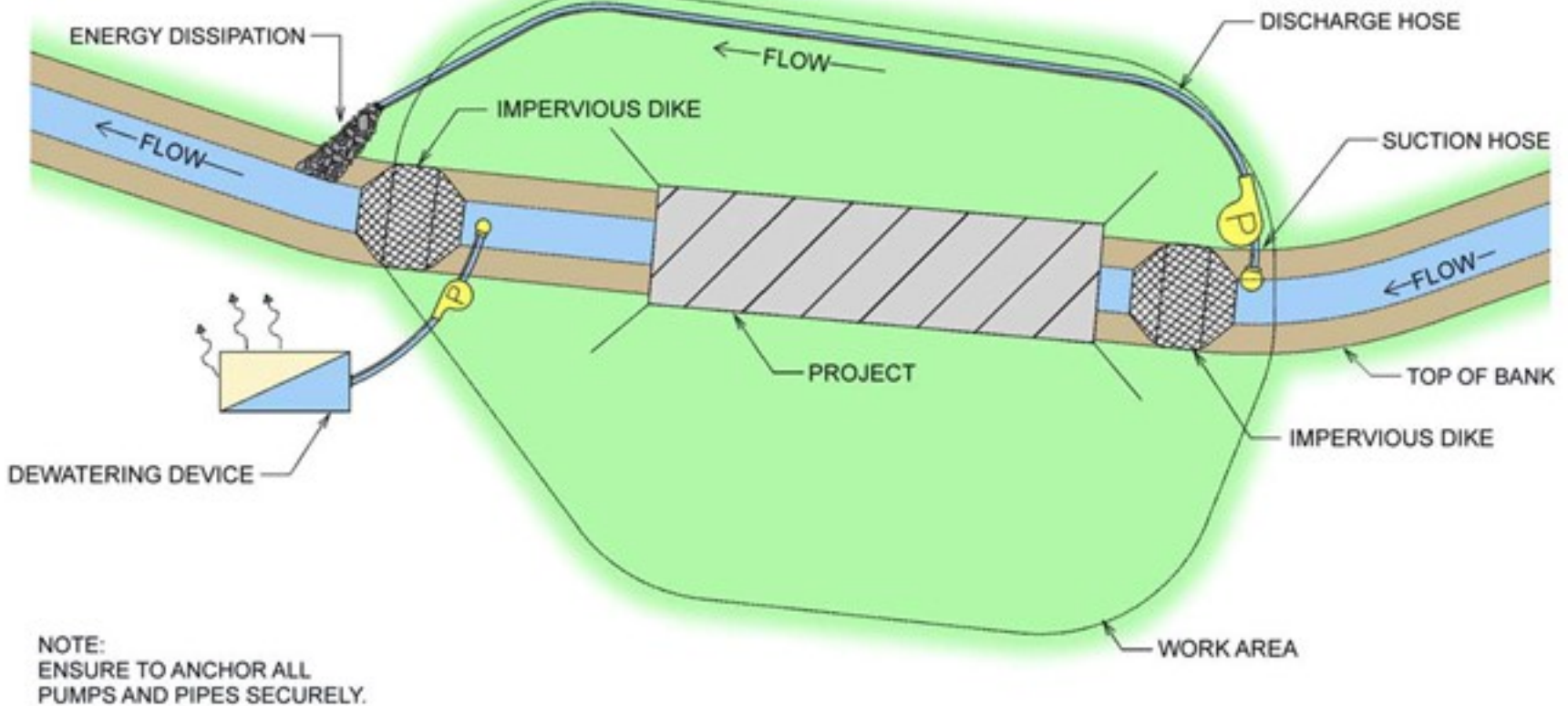

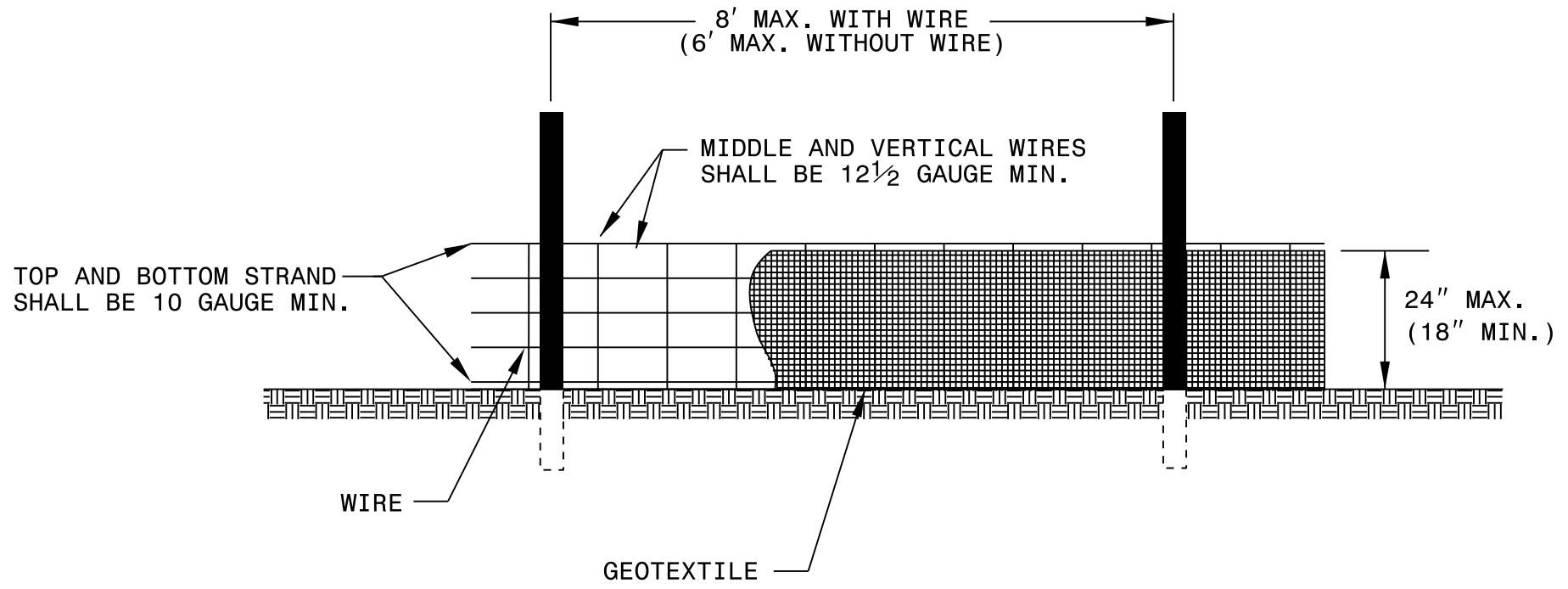

NOTES

USE GEOTEXTILE A MINIMUM OF 36" IN WIDTH AND FASTEN ADEQUATELY TO THE POSTS AND WIRE AS DIRECTED.

USE WIRE A MINIMUM OF 32" IN WIDTH AND WITH A MINIMUM OF 5 LINE WIRES WITH 12" VERTICAL SPACING.

PROVIDE 5'-0" STEEL POST OF THE SELF-FASTENER ANGLE STEEL TYPE.

FOR MECHANICAL SLICING METHOD INSTALLATION, GEOTEXTILE SHALL BE A MAXIMUM OF 18" ABOVE GROUND SURFACE.

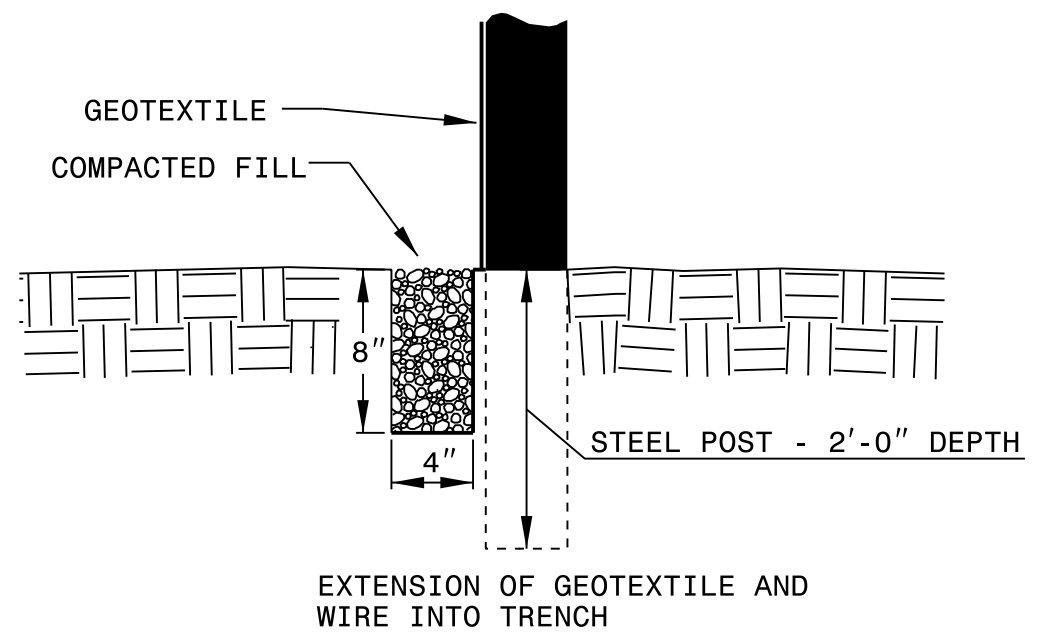

PROJECT REFERENCE NO.	SHEET NO.
RW SHEET NO.	
ROADWAY DESIGN ENGINEER	HYDRAULICS ENGINEER

WATTLE WITH POLYACRYLAMIDE DETAIL

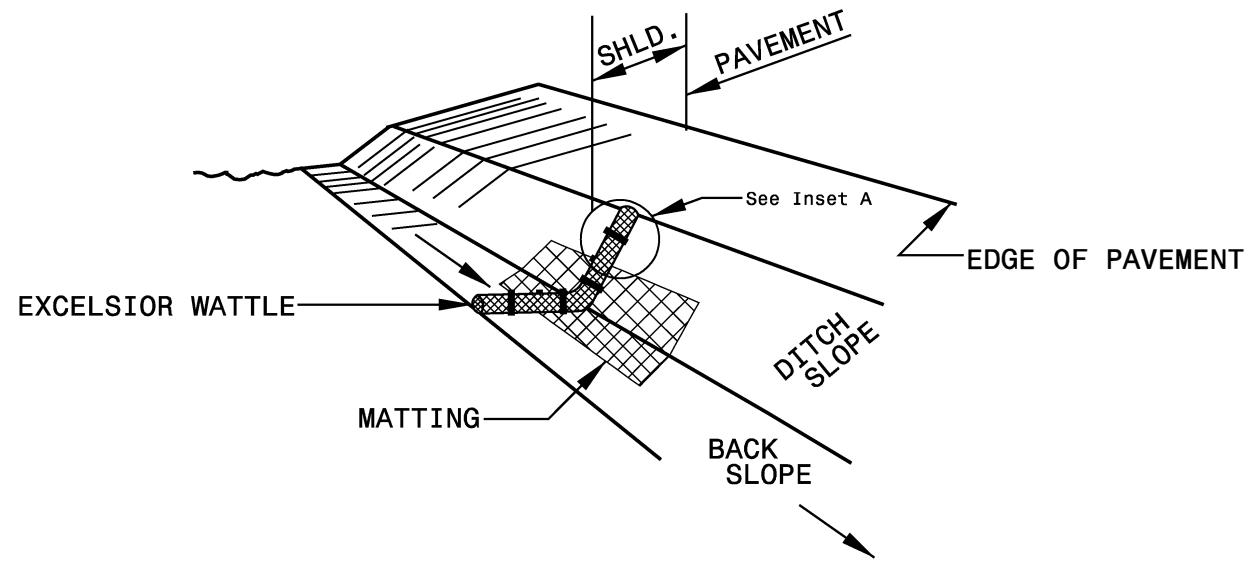

ISOMETRIC VIEW

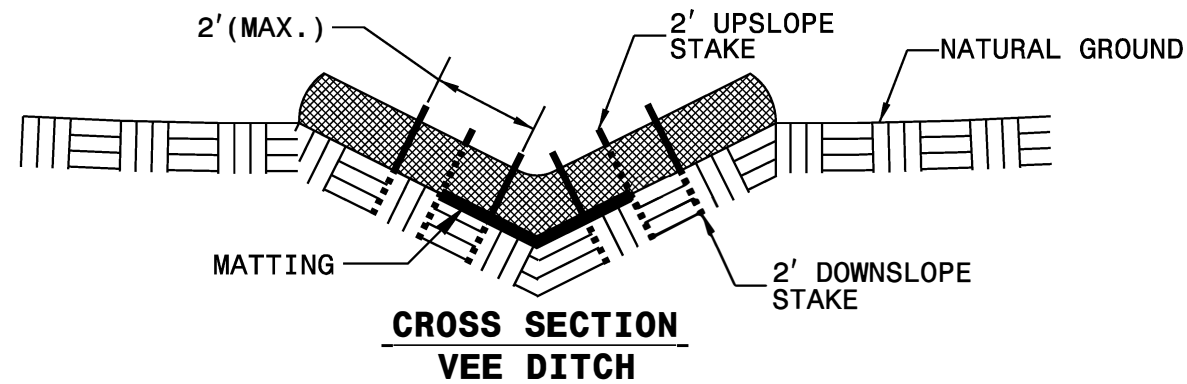

CROSS SECTION VEE DITCH

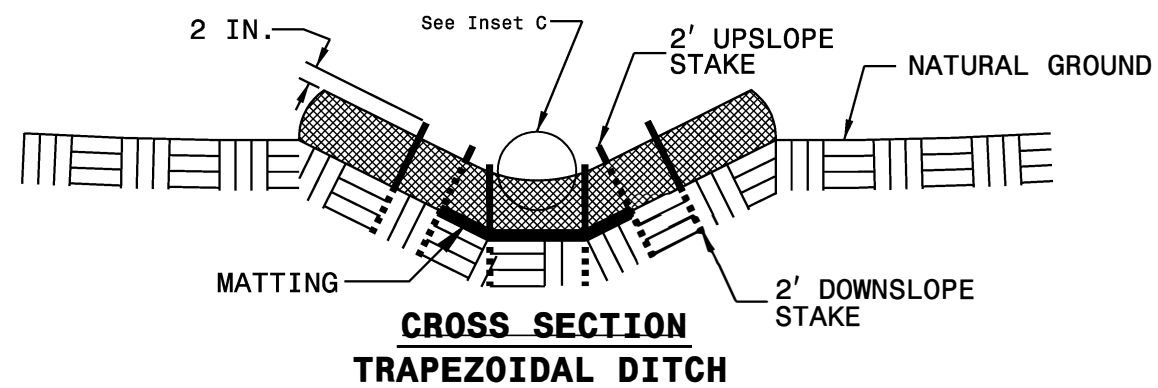

CROSS SECTION TRAPEZOIDAL DITCH

NOTES:

- USE MINIMUM 12 IN. DIAMETER EXCELSIOR WATTLE.
- USE 2 FT. WOODEN STAKES WITH A 2 IN. BY 2 IN. CROSS SECTION.
- INSTALL A MINIMUM OF 2 UPSLOPE STAKES AND 4 DOWNSLOPE STAKES AT AN ANGLE TO WEDGE WATTLE TO BOTTOM OF DITCH.
- PROVIDE STAPLES MADE OF 0.125 IN. DIAMETER STEEL WIRE FORMED INTO A U SHAPE NOT LESS THAN 12" IN LENGTH.
- INSTALL STAPLES APPROXIMATELY EVERY 1 LINEAR FOOT ON BOTH SIDES OF WATTLE AND AT EACH END TO SECURE IT TO THE SOIL.
- INSTALL MATTING IN ACCORDANCE WITH SECTION 1631 OF THE STANDARD SPECIFICATIONS.
- INITIALLY APPLY 3.5 OUNCES OF ANIONIC OR NEUTRALLY CHARGED POLYACRYLAMIDE (PAM) OVER WATTLE WHERE WATER WILL FLOW AND AFTER EVERY RAINFALL EVENT THAT IS EQUAL TO OR EXCEEDS 0.25 IN.

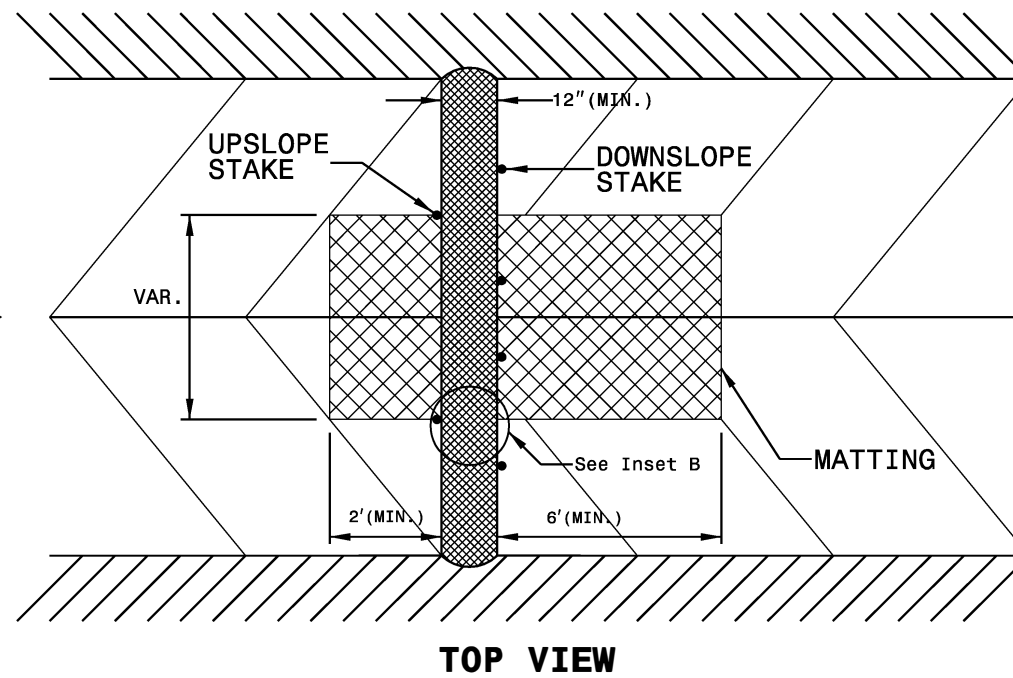
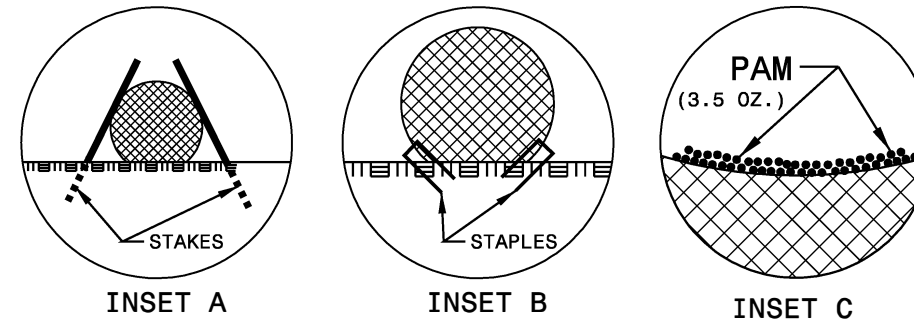

TOP VIEW

TYPICAL BACKFILL SECTION

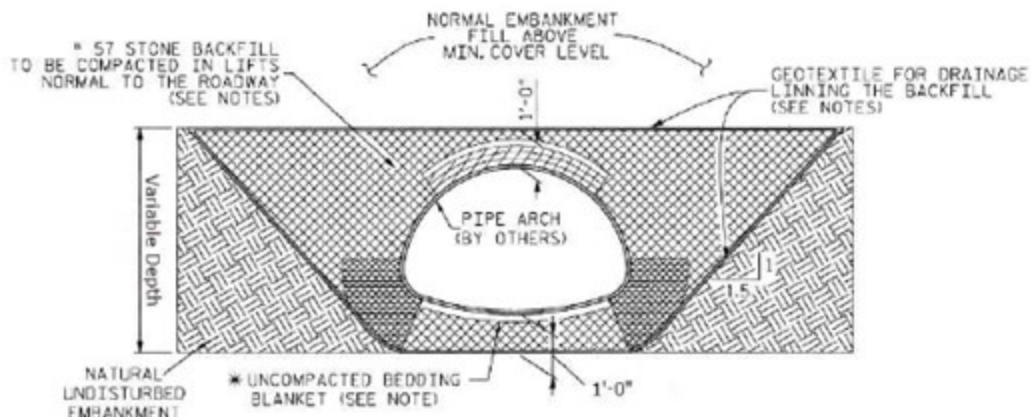

 CRITICAL BACKFILL ZONE, PRESSURE ON SOIL GREATEST HERE.

 INITIAL LIFTS OVER CROWN OF STRUCTURE AS INDICATED BY
 SHADED AREA TO BE COMPACTED TO REQUIRED DENSITY WITH
HAND OPERATED EQUIPMENT

 * # 57 STONE BACKFILL LIMITS.

NOTES:

ALL BACKFILL TO BE PLACED IN A BALANCED FASHION IN THIN LIFTS (6"-8" LOOSE TYPICALLY) AND COMPACTED TO 90 PERCENT DENSITY PER AASHTO T-180.

GEOTEXTILE FOR DRAINAGE IN FOUNDATION BEDDING AND BACKFILL IS INCIDENTAL TO COST OF PIPE ARCH.

COMPLETE AND REGULAR MONITORING OF THE CSP ARCH SHAPE IS NECESSARY DURING ALL BACKFILLING OF THE STRUCTURE.

PREVENT EXCESSIVE DISTORTION OF SHAPE AS NECESSARY BY VARYING COMPACTION METHODS AND EQUIPMENT.

* SHAPED BED FOR A MINIMUM WIDTH OF $SPAN/2$. MINIMUM BEDDING THICKNESS IS TWICE THE CORRUGATION DEPTH.

EMBANKMENT SLOPE TO BE 1.5:1 MINIMUM SUCH THAT A STABLE EMBANKMENT CAPABLE OF RESISTING SIDE PRESSURES FROM CSP PIPE-ARCH SHAPE WILL BE MAINTAINED THROUGHOUT THE LIFE OF INSTALLATION.

TYPICAL BACKFILL SECTION ALONG PIPE